



The new degree of comfort.®



Residential Gas  
ThermaForce Super High Efficiency  
Condensing Boilers

# Rheem® ThermaForce™ Super High-Efficiency Condensing Boilers

## Flexible Installation

- Moveable combustion air intake (left/right) and ability to flex vent in existing B-vent
- Extra long pipe fittings with notched sides for easy gripping with wrench
- Only 4 moving parts – Fan, Pump, Gas Valve, and Damper
- Universal shared platform parts – Easily diagnose and service with common parts for all ThermaForce™ units

## Key Features

- Innovative single pass Labyrinth Heat Exchanger with Integrated copper waterways ensures maximum heat transfer and minimal heat loss
- Built-in ECM variable speed, high efficiency boiler pump
- Built-in Illuminated Touchscreen Control Panel
- Outdoor reset technology increases efficiency by lowering water temperature automatically
- Wireless cascading using RF balances workload of each unit for longer life
- ENERGY STAR® certified with up to 96% AFUE and ASME-rated

## Specifications

MODEL NO.		RHBH-L99i	RHBH-L120i
Input Rate	MAX	99,000 BTU/h	120,000 BTU/h
	MIN	15,500 BTU/h	13,650 BTU/h
Output Rate	MAX	89,000 BTU/h	108,000 BTU/h
	MIN	14,800 BTU/h	13,000 BTU/h
AFUE		96%	95%
Gas Pressure (Nat Gas or LP gas)	MAX	14" WC	
	MIN	4" WC	
Power Supply		120V/60Hz	
Weight lbs. (empty)		85	
Pressure vessel water content – USG		0.5	
Boiler Flow Rate – GPM	MAX	10	11
	MIN	2	
Water Pressure	MAX	43.5psi	
	MIN	8psi	
Maximum Altitude		10,100 ft	
Ambient temperature – Low (°F)		32°	
Ambient temperature – High (°F)		122°	
Max relative humidity (non-condensing)		90%	
Temperature Range		51°F - 194°F	
Gas Connection		3/4" Male NPT	
Max equivalent vent length 2" (each side) <sup>2</sup>		65'	
Max equivalent vent length 3" each side		120'	
Ultra Low NOx		Meets 14 ng/J NOx requirements - SCAQMD Rule 1146.2 compliant	
Warranty <sup>1</sup>		10-Year Heat Exchanger, 5-Year Parts, 1-Year Labor	

<sup>1</sup>See Warranty Certificate for complete information. <sup>2</sup>Approximate input derate of 5 - 16% at 2" maximum vent length.

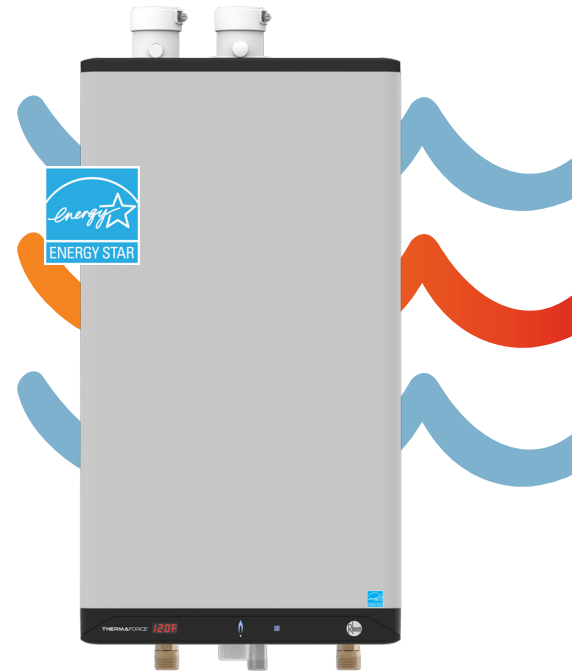

**RHBH-L99i & RHBH-L120i**  
Indoor Direct Vent  
99,000-120,000 BTU/h  
Natural Gas/LP Convertible



INTEGRATED HOME COMFORT



The new degree of comfort®



Residential Gas  
ThermaForce Super High Efficiency  
Condensing Boilers

**View the boiler head loss – ThermaForce™ RHBH-L99i & RHBH-L120i**

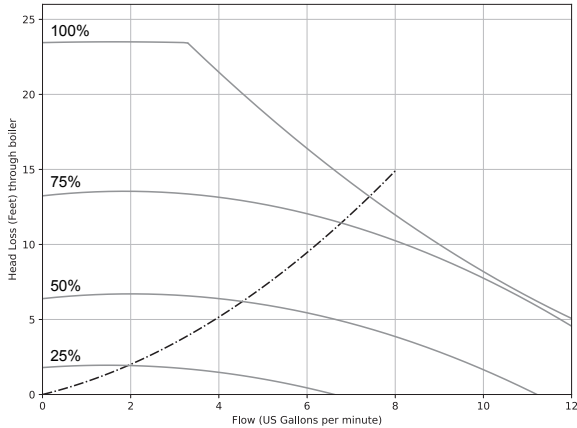

**Specifications**

VENTING	MAX EQUIVALENT LENGTH
<b>Schedule 40 PVC, CPVC, or Polypropylene</b>	(each side)
2"	65' <sup>2</sup>
3"	120'
2" or 3" 90° Long Sweep Vent Elbow	Allow 5 equivalent feet
2" or 3" 90° Short Sweep Vent Elbow	Allow 8 equivalent feet
2" or 3" 45° Vent Elbow	Allow 3 equivalent feet
<b>Polypropylene</b>	
PPs 87-90° Elbow	Allow 8 equivalent feet
<b>Flex PPs</b>	
3" PPs Flex	35' Actual (Equivalent = Actual x 1.4)

<sup>2</sup> Approximate input derate of 5 - 16% at 2" maximum vent length.

SURFACE	MIN. DISTANCE FROM COMBUSTIBLE SURFACES	RECOMMENDED DISTANCE FOR INSTALLATION AND SERVICE
Front	2"	24"
Rear	0"	0"
Left Side	1.5"	6"
Right Side	4"	6"
Top	2"	24"
Bottom	8"	24"

	PIPING CONNECTIONS	DIMENSION
A	Exhaust Outlet	2" Schedule 40 PVC
B	Combustion Air Inlet	2" Schedule 40 PVC
C	Heating Water Inlet	1" Male NPT
D	Heating Water Outlet	1" Male NPT
E	Gas Inlet	3/4" Male NPT
F	Condensate Outlet	3/4" Hose
G	Control Wiring	7/16" Rubber Plug

**Dimensions**

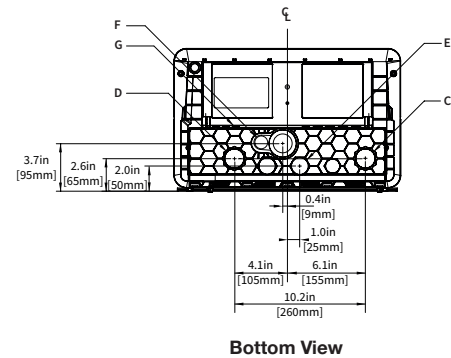
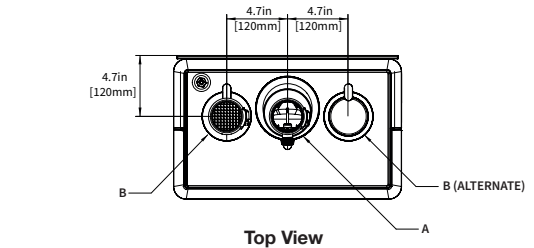
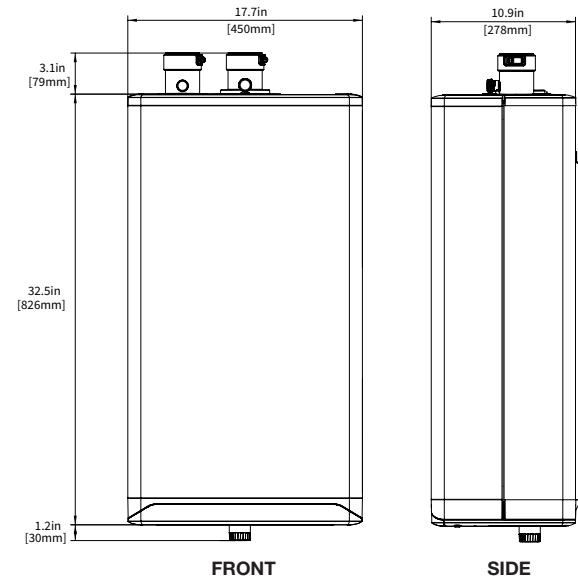

**Parts & Accessories**

Floor Stand P-267C	Service Parts Kit P-911R	EZ Pipe Manifold 251-063	2" PVC Sidewall Vent Kit P-741	3" PVC Sidewall Vent Kit P-742

In keeping with its policy of continuous progress and product improvement, Rheem reserves the right to make changes without notice.

Rheem Water Heating • 1115 Northmeadow Parkway, Suite 100  
Roswell, Georgia 30076 • www.rheem.com

Rheem Canada Ltd./Ltée • 125 Edgeware Road, Unit 1  
Brampton, Ontario L6Y 0P5 • www.rheem.ca



INTEGRATED HOME COMFORT